

ABAKUS® MOBIL FLUID

Particle counter for oil and liquids

Agence Nord:

ZA Object'ifs Sud - Lot A3
6 Allée Emilie du Châtelet
14123 Ifs
tél : 02.31.34.50.74
fax : 02.31.34.55.17

Agence Sud:

Bât Le Venango, 392 Rue Jean Dausset
AGROPARC - BP11575
84916 Avignon Cédex 9
tél : 04.90.27.17.95 fax : 04.90.27.17.52

Agence Est:

Parc Club des Tanneries
2 Rue de la Faisanderie
67380 Lingolsheim
tél : 03.88.04.01.81
fax : 03.68.93.01.52



www.deltalabo.fr
info@deltalabo.fr



KLOTZ®

Particle measuring systems for liquids, air, gases, oils and particle sizes.

ABAKUS® MOBIL FLUID

Particle counter for oil and liquids

The particle measuring system Abakus® mobil fluid with tank (Amf) is used for counting particles in liquids from pressure lines and from bottles. The particle number is displayed in 32 size classes, printed out, stored and transmitted to the interface.

The laser sensor LDS 45/50 is used for contamination control of oils. An LDS 30/30 can be used optionally for the contamination control of diesel and kerosene. Concentrations of up to 200,000 p/ml are possible with it. For the monitoring of cleaning baths the sensor LDS 1/1 is used. The sensor can be operated with a higher flow rate. The LDS sensor features a high reproducibility rate and good resolution. The integrated double piston pump works independently from the input pressure and viscosity. The particle counter Amf can work from lab bottles, from tank systems and from pressure lines.



Big user-friendly touch screen

Software:

With the evaluation software "Log and Show" the measuring results can be exported via the built-in interface to the PC and further processed. Direct measuring and storing via the software is also possible (including Excel export of data).

Option:

Pressure reducing valve and tank for oils.



integrated printer and interfaces

Technical Specifications

Standards:

According to ISO4406(91/99), NAS1638, GB593086, GJB42087, GJB420A96, GJB420B, GOST 1721671, SAE46D, SAE749D, SAEAS4059D, SAEAS4059E or 32 freely definable size channels

Measuring value readout:

PC, display, printer, threshold readout, external memory

Software:

LAS 4.3 for oil
LAS 3.2 for water

DPS pump:

Stroke volume: 10ml
Rinsing/measuring volume: 10-1000 ml
Supply pressure: 10bar; 315bar mit DMV

Ambient temperature:

5 – 40°C

Medium temperature:

0 – 70°C

Power Supply:

230/115 V/AC, 50/60Hz; battery pack

Connector:

Minimess (M16x3; 6mm Ermeto (L))

Dimensions Amf touch (h x w x d):

220 x 350 x 220 mm, 7.8kg

Accessories:

Sample feeder for the pressurization of sample bottles

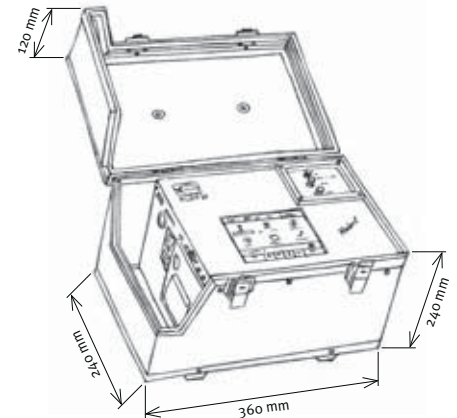

Particle sensors

Model	Flow rate [ml/min]	Measuring range [μ m]	Cell sizes [μ m]	max. conc. /ml
LDS 45/50	30ml/min	4-100	450 x 500	60.000
LDS 30/30	20ml/min	1-400 (latex in water) 4-100 (ISOMTD)	300 x 300	120.000
LDS 1/1	50ml/min	5-500	1.000 x 1.000	4.000

Areas of application

Contamination control of hydraulic oils (bottle samples or sampling from pressure lines), testing of diesel fuels and kerosene, contamination control of transmission oils. The measuring unit is suitable for online measuring, for measuring in the lab and for on-site mobile measuring due to its compact design.

Option: battery operation

Agence Nord:

ZA Object'ifs Sud - Lot A3
6 Allée Emilie du Châtelet
14123 Ifs
tél : 02.31.34.50.74
fax : 02.31.34.55.17

Agence Sud:

Bât Le Venango. 392 Rue Jean Dausset
AGROPARC - BP11575
84916 Avignon Cédex 9
tél : 04.90.27.17.95 fax : 04.90.27.17.52



Agence Est:

Parc Club des Tanneries
2 Rue de la Faisanderie
67380 Lingolsheim
tél : 03.88.04.01.81
fax : 03.68.93.01.52

www.deltalabo.fr
info@deltalabo.fr